

Order picking truck 1.0 ton

BT optio

L & M-series

OSE100

OSE100W

OME100N

OME100NW



Order picking truck

Truck specifications					OSE100	OSE100W	OME100N	OME100NW
Identification	1.1	Manufacturer			BT	BT	BT	BT
	1.2	Model			OSE100	OSE100W	OME100N	OME100NW
	1.3	Drive			Electric	Electric	Electric	Electric
	1.4	Operator type			Stand on	Stand on	Stand on	Stand on
	1.5	Load capacity/rated load	Q	kg	1000	1000	1000	1000
	1.6	Load centre	c	mm	600	600	600	600
	1.8	Load distance, back of fork to wheel centre	x	mm	158	110	158	110
	1.9	Wheelbase	y	mm	1351	1300	1401	1350
Weight	2.1	Service weight without battery		kg	1294	1162	1577 ¹⁾	1607
	2.2	Axle load, with load, drive/support arm wheels		kg	550/1149	558/1112	615/1280	639/2459
	2.3	Axle load, without load, drive/support arm wheels		kg	1113/365	1105/338	1235/450	1208/884
Wheels	3.1	Drive / castor / fork wheels			Vulkollan	Vulkollan	Vulkollan	Vulkollan
	3.2	Wheel size, front		mm	250 x 105	250 x 105	250 x 105	250 x 105
	3.3	Wheel size, rear		mm	140 x 80	140 x 80	140 x 80	140 x 80
	3.4	Additional wheels, dimensions		mm	—	—	—	—
	3.5	Wheels, number front / rear (x =driven wheels)		mm	1x/2	1x/2	1x/2	1x/2
Dimensions	4.2	Height, mast lowered	h_1	mm	1550	1550	2450	2450
	4.4	Lift movement	h_3	mm	1020	1020	1620	1620
		Lift height	h_{23}	mm	1880	1100	2480	1700
	4.5	Height, mast extended	h_4	mm	2570	2570	4070	4070
	4.8	Stand height	h_7	mm	180	180	180	180
	4.11	Additional lift	h_9	mm	780	—	780	—
	4.14	Stand height, elevated	h_{12}	mm	1200	1200	1800	1800
	4.15	Height, fork lowered	h_{13}	mm	80	80	80	80
	4.19	Overall length	l_1	mm	2840	2744	2890	2798
	4.20	Length to face of forks	l_2	mm	1690	1594	1740	1648
	4.21	Overall width	b_1	mm	790	790	810	810
	4.22	Fork dimensions	s/e/l	mm	62/115/1150	62/115/1150	62/115/1150	62/115/1150
	4.25	Width over forks	b_5	mm	300-750	560, 655, 776	300-750	560, 655, 776
	4.32	Ground clearance, centre of wheelbase	m_2	mm	70	70	55	55
4.35	Turning radius	W_a	mm	1540	1490	1590	1540	
4.44	Clear width driver compartment entrance	l_{24}	mm	490	—	490	490	
Performance data	5.1	Travel speed, with/without load ¹⁾		km/h	7,0/12,0	8,0/12,0	7,0/12,0	7,0/12,0
	5.2	Lift speed, with/without load		m/s	0,12/0,19	0,12/0,19	0,12/0,19	0,12/0,19
	5.3	Lowering speed, with/without load		m/s	0,33/0,36	0,33/0,36	0,12/0,19	0,12/0,19
	5.8	Max. gradeability, with/without load ²⁾		%	9/13	9/13	5/6	5/6
	5.10	Service brake			Electromagnetic	Electromagnetic	Electromagnetic	Electromagnetic
Electric motor	6.1	Drive motor rating S2 60 min		kW	2,8	2,8	2,8	2,8
	6.2	Lift motor rating S3 5%		kW	2,2	2,2	2,2	2,2
	6.4	Battery voltage, nominal capacity K_5		V/Ah	24/465-620	24/465-620	24/465-620	24-465-620
	6.5	Battery weight, min./max.		kg	475-530	470-530	475-530	475-530
	6.6	Energy consumption acc to VDI cycle ³⁾		kWh/h				
	Other	8.1	Type of drive control			BT Powerdrive	BT Powerdrive	BT Powerdrive
8.4		Sound level at the driver's ear according to EN 12 053		dB(A)	60	60	60	60

1) With small battery, add 125 kg counterweight.

2) Measured according to company standard.

3) Contact your supplier for information.

*) Travel speed in fork direction: 6,0/10,5 km/h for all models.

All data are based on table configuration. Other configurations may give other values.

Truck performance and dimensions are nominal and subject to tolerances.

BT products and specifications are subject to change without notice.

Dimensional drawings

OSE100

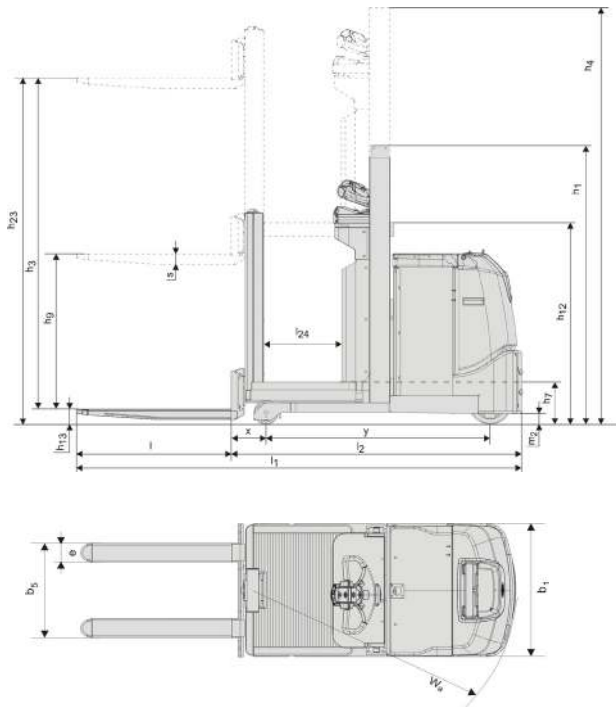

OSE100W

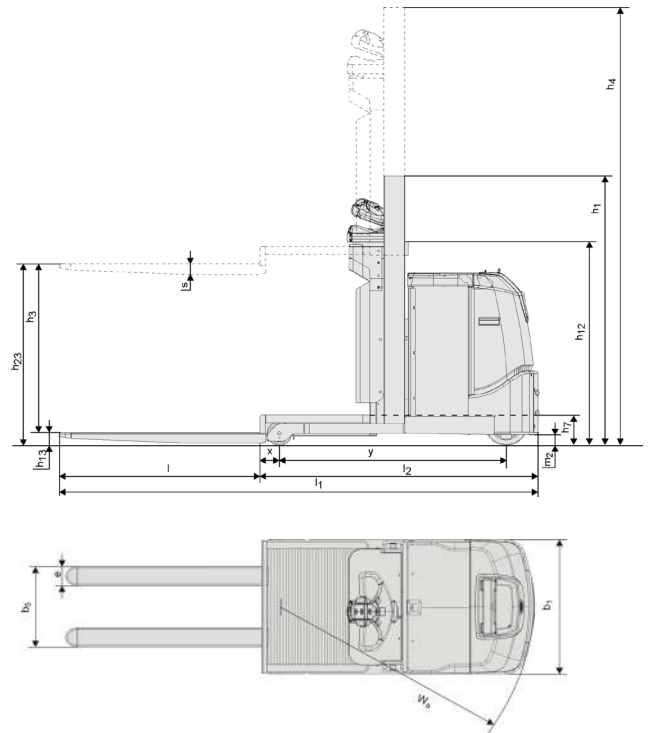

OME100N

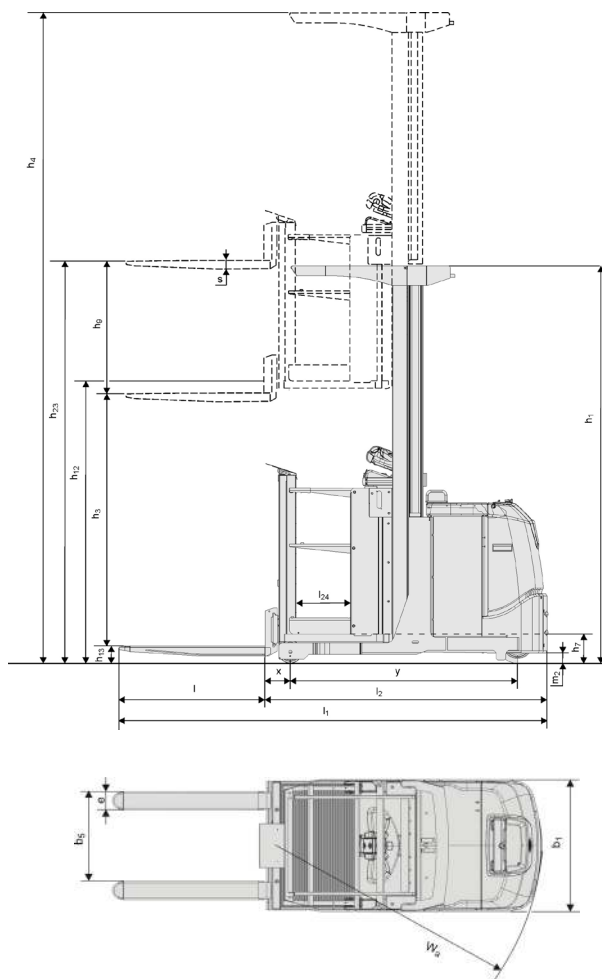

OME100NW

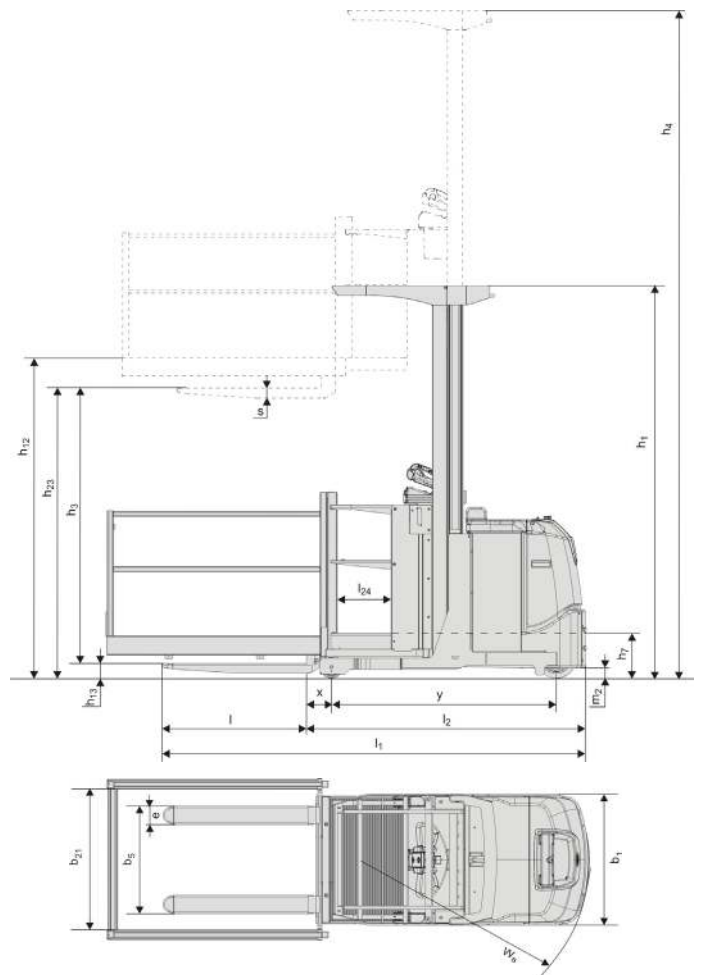

Truck features:

- High performance models
- BT E-man steering concept
- Low step-in
- Man-up possibilities
- BT Powerdrive system
- Integrated shrink film holder
- Streamlined administration
 - E-bar concept (option)

