

Order picking truck 1.2 ton

BT optio *L-series* OSE120CB



Order picking truck

Truck specifications						OSE120CB	
Identification	1.1	Manufacturer					BT
	1.2	Model					OSE120CB
	1.3	Drive					Electric
	1.4	Operator type					Stand on
	1.5	Load capacity/rated load		Q	kg		1200
	1.6	Load centre		c	mm		500
	1.8	Load distance, back of fork to wheel centre		x	mm		73
	1.9	Wheelbase		y	mm		1448
Weight	2.1	Service weight without battery			kg		1599 ¹⁾
	2.2	Axle load, with load, drive/support arm wheels			kg		615/2725
	2.3	Axle load, without load, drive/support arm wheels			kg		1100/1038
Wheels	3.1	Drive / castor / fork wheels					Vulkollan
	3.2	Wheel size, front			mm		Ø 250 x 105
	3.3	Wheel size, rear			mm		Ø 140 x 80
	3.4	Additional wheels, dimensions			mm		—
	3.5	Wheels, number front / rear (x =driven wheels)					1x/2
Dimensions	4.2	Height, mast lowered		h_1	mm		1841
	4.4	Lift movement		h_3	mm		2650
		Lift height		h_{23}	mm		2700
	4.5	Height, mast extended		h_4	mm		3280
	4.7	Height of overhead guard		h_6	mm		2196
	4.8	Stand height		h_7	mm		130
	4.15	Height, fork lowered		h_{13}	mm		50
	4.19	Overall length		l_1	mm		2853
	4.20	Length to face of forks		l_2	mm		1703
	4.21	Overall width		b_1/b_2	mm		790/861
	4.22	Fork dimensions		$s/e/l$	mm		40/100/1150
	4.25	Width over forks		b_5	mm		250-570
	4.31	Ground clearance, below mast		m_1	mm		49
	4.32	Ground clearance, centre of wheelbase		m_2	mm		72
	4.34	Aisle width for pallets 800 x 1200 lengthways		A_{st}	mm		3170
	4.35	Turning radius		W_a	mm		1636
4.44	Clear width driver compartment entrance		l_{24}	mm		450	
Performance data	5.1	Travel speed, with/without load			km/h		7,0/12,0
	5.2	Lift speed, with/without load			m/s		0,12/0,27
	5.3	Lowering speed, with/without load			m/s		0,33/0,36
	5.8	Max. gradeability, with/without load ²⁾			%		9/13
	5.10	Service brake					Electromagnetic
Electric motor	6.1	Drive motor rating S2 60 min			kW		2,8
	6.2	Lift motor rating S3 6%			kW		2,2
	6.4	Battery voltage, nominal capacity K_5			V/Ah		24/465-620
	6.5	Battery weight, min./max.			kg		338/501
	6.6	Energy consumption acc to VDI cycle ³⁾			kWh/h		
	Other	8.1	Type of drive control				
8.4		Sound level at the driver's ear according to EN 12 053			dB(A)		62

1) With small battery, add 125 kg counterweight.

2) Measured according to company standard.

3) Contact your supplier for information.

All data are based on table configuration. Other configurations may give other values.

Truck performance and dimensions are nominal and subject to tolerances.

BT products and specifications are subject to change without notice.

Mast dimensions

BT optio

OSE120CB			Simplex			Duplex Tele					Duplex HiLo				
h_{23}	Lift height ($h_{13}+h_3$)	mm	1400	1700	1800	2700	2900	3300	3700	4150	2700	2900	3300	3700	4150
h_3	Lift	mm	1350	1650	1750	2650	2850	3250	3650	4100	2650	2850	3250	3650	4100
h_1	Height, mast lowered	mm	1820	2120	2220	1841	1941	2141	2341	2475	1836	1936	2136	2336	2561
h_2	Free lift	mm	1400	1700	1800	110	110	110	110	110	1396	1496	1696	1896	2121
h_4	Height, mast extended	mm	1980	2280	2380	3280	3480	3880	4280	4720	3280	3480	3880	4280	4720

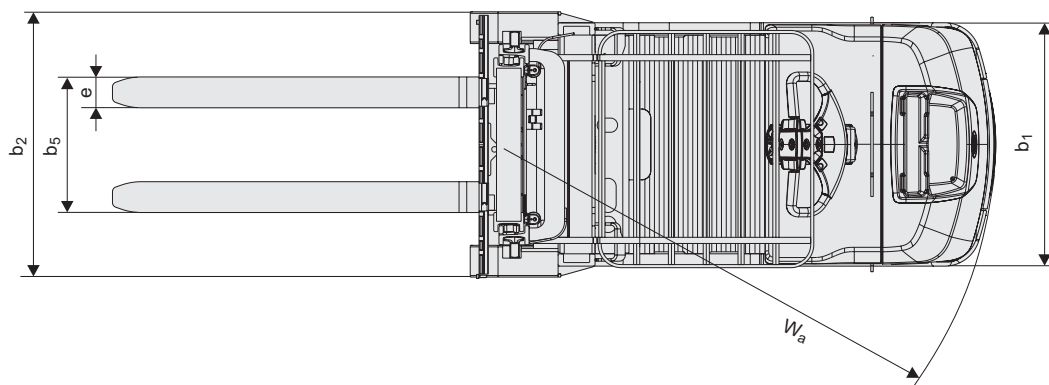
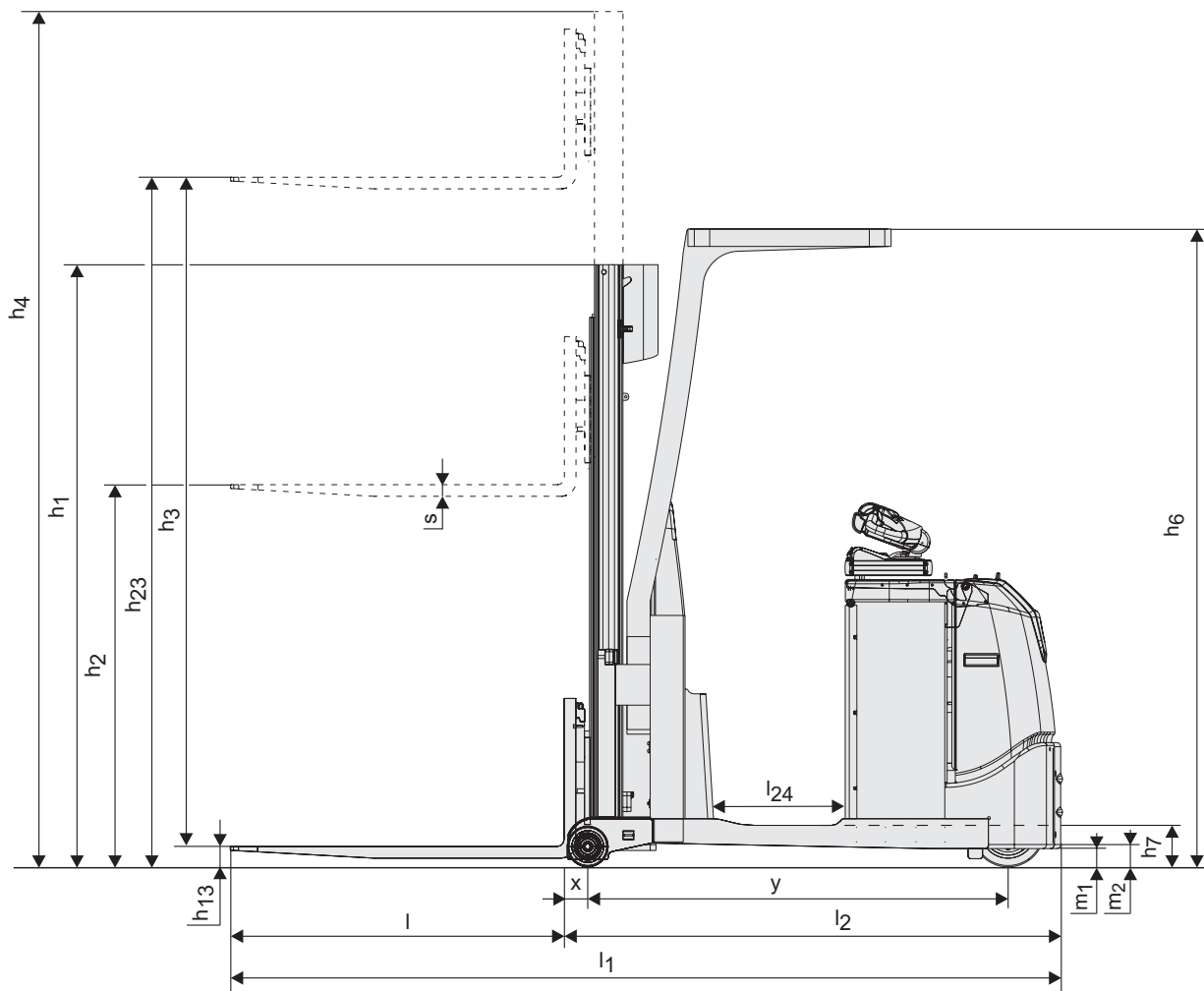

Truck features:

- High performance models
- BT E-man steering concept
- Low step-in
- Stacking possibilities
- 2-step lowering system
- BT Powerdrive system
- Integrated shrink film holder
- Streamlined administration
— E-bar concept (option)
- Frequency adapted suspension (option)

