

Stand-on stacker truck 1.6 ton

BT staxio

S-series

SSE160D



Stand-on stacker truck

Specifications					SSE160D
Identification	1.1	Manufacturer			BT
	1.2	Model			SSE160D
	1.3	Drive			Electric
	1.4	Operator type			Stand on
	1.5	Load capacity/rated load/support arm lift	Q	kg	1200/1600
	1.6	Load centre	c	mm	600
	1.8	Load distance, front axle to front face, fork raised/lowered	x	mm	892
Weight	2.1	Service weight without battery		kg	901
	2.2	Axle load, with load, drive/castor/support arm wheels		kg	1295/1300
	2.3	Axle load, without load, drive/castor/support arm wheels		kg	1053/342
Wheels	3.1	Drive/castor/fork wheel			Vulkollan
	3.2	Wheel size, front		mm	Ø 80
	3.3	Wheel size, rear		mm	Ø 250
Dimensions	4.2	Height, mast lowered	h_1	mm	1330
	4.3	Free lift	h_2	mm	160
	4.4	Lift	h_3	mm	1585
		Lift height	h_{23}	mm	1675
	4.5	Height, mast extended	h_4	mm	2090
	4.6	Initial lift	h_5	mm	120
	4.8	Instep height	h_7	mm	254
	4.15	Height, fork lowered	h_{13}	mm	90
	4.19	Overall length	l_1	mm	2229
	4.20	Length to face of forks	l_2	mm	1079
	4.21	Overall width	b_1	mm	770
	4.22	Fork dimensions	s/e/l	mm	60/180/1150
	4.25	Width over forks	b_5	mm	570
	4.32	Ground clearance, under mast, min.-max.	m_1	mm	17-137
4.35	Turning radius	W_a	mm	1992	
Performance data	5.1	Travel speed, with/without load		km/h	8,0/10,0
	5.2	Lift speed, with/without load		m/s	0,11/0,18
	5.3	lowering speed, with/without load		m/s	0,15/0,13
	5.8	Max. gradeability, with/without load ¹⁾		%	8/10
	5.10	Service brake			Electromagnetic
Electric motor	6.1	Drive motor rating S2 60 min		kW	2,2
	6.2	Lift motor rating at S3 5%		kW	2,2
	6.4	Battery voltage/nominal capacity K_5		V/Ah	48/450
	6.5	Battery weight, min./max.		kg	375-420
Others	8.1	Type of drive control			Stepless

1) Measure according to company standard.

All data are based on table configuration. Other configurations may give other values.

Truck performance and dimensions are nominal and subject to tolerances.

BT products and specifications are subject to change without notice.

Mast dimensions

BT staxIO

SSE160D			Duplex Tele	
h_{23}	Lift height	mm	1675	
h_1	Height, mast lowered	mm	1330	
h_2	Free lift	mm	160	
h_4	Height, mast extended	mm	2090	

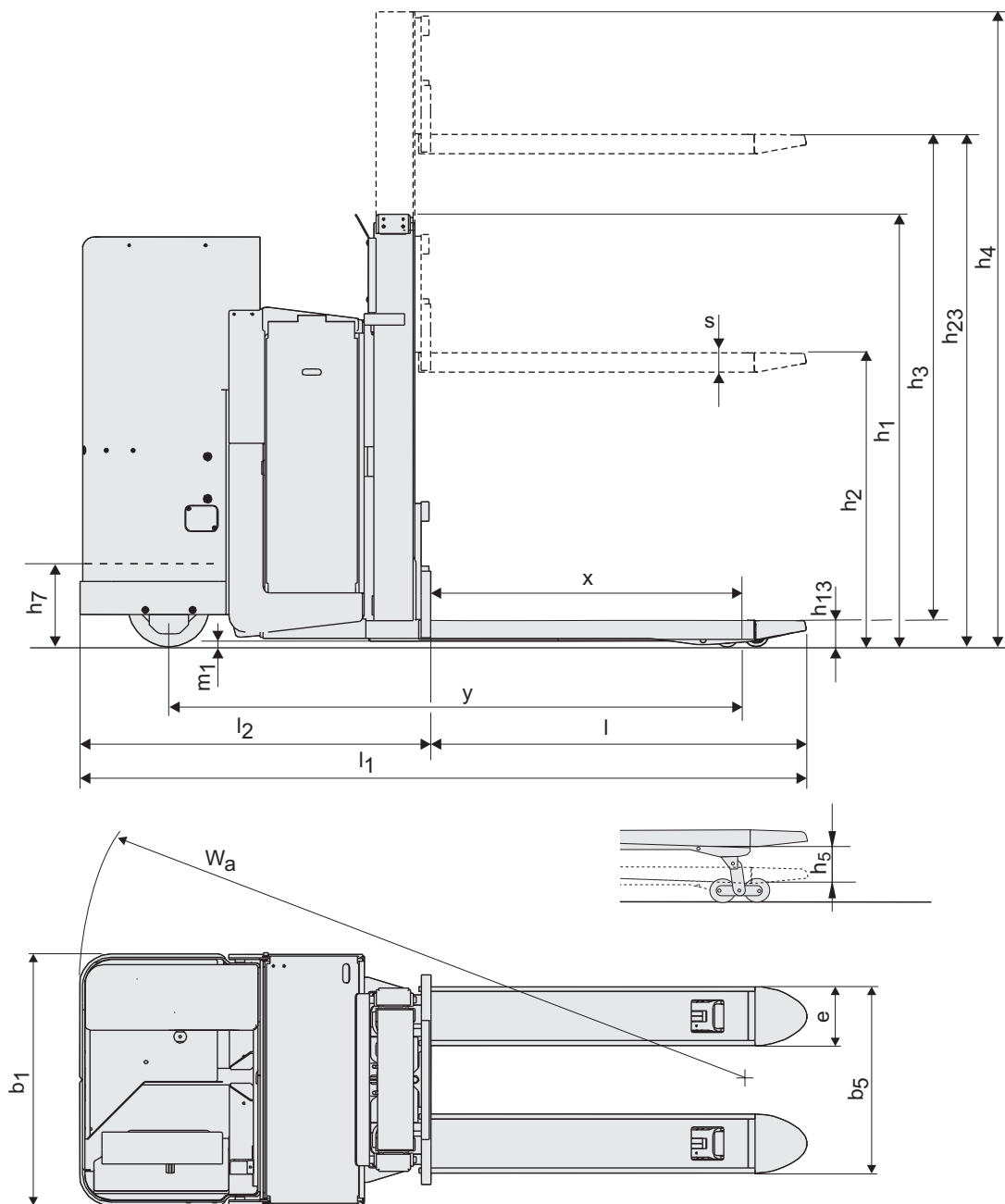

Truck features:

- Double pallet handling
- Elevating support arms
- Fingertip controls
- Electronic steering
- Automatic deceleration
- Driver detection system
- Adjustable backrest
- Easy access for maintenance
- Sideways battery change

