

# Order picking truck 1.0 ton

## BT optio

*M-series*

OME100M

OME100



# Order picking truck

Truck specifications					OME100M	OME100
Identification	1.1	Manufacturer			BT	BT
	1.2	Model			OME100M	OME100
	1.3	Drive			Electric	Electric
	1.4	Operator type			Stand on	Stand on
	1.5	Load capacity/rated load	Q	kg	850/1000	850/1000
	1.6	Load centre	c	mm	600/500	600/500
	1.8	Load distance, centre of load axle to fork	x	mm	225 <sup>1)</sup>	225 <sup>1)</sup>
	1.9	Wheelbase	y	mm	1441	1441
Weight	2.1	Service weight with battery		kg	2000	1740
	2.2	Axle load, with load, drive/fork wheel		kg	697/1228	609/1135
	2.3	Axle load, without load, drive/fork wheel		kg	1176/490	1058/410
Wheels	3.1	Drive/fork wheel			Vulkollan	Vulkollan
	3.2	Wheel size, front		mm	Ø 230 x 85	Ø 230 x 85
	3.3	Wheel size, rear		mm	Ø 250 x 75	Ø 250 x 75
	3.5	Wheels, number front/rear (x=driven wheels)			2/1 (*)	2/1 (*)
	3.6	Track width, front	b <sub>10</sub>	mm	850	850
	Dimensions	4.2	Height, mast lowered	h <sub>1</sub>	mm	2650
4.4		Lift	h <sub>3</sub>	mm	3900	1450
		Lift height	h <sub>23</sub>	mm	4760	2310
4.5		Height, mast extended	h <sub>4</sub>	mm	6350	2940
4.7		Height of overhead guard (cab)	h <sub>6</sub>	mm	2390	—
4.8		Stand height	h <sub>7</sub>	mm	300	300
4.11		Initial lift movement	h <sub>9</sub>	mm	780	780
4.14		Stand height, elevated	h <sub>12</sub>	mm	4200	1750
4.14.1		Picking height (h <sub>12</sub> + 1600 mm)	h <sub>28</sub>	mm	5800	3350
4.19		Overall length	l <sub>1</sub>	mm	2670	2670
4.20		Length to face of forks	l <sub>2</sub>	mm	1870 <sup>1)</sup>	1870 <sup>1)</sup>
4.21		Overall width <sup>2)</sup>	b <sub>1</sub> /b <sub>2</sub>	mm	970/1000	970/1000
4.22		Fork dimensions	s/e/l	mm	62/115/800	62/115/800
4.25		Width over forks	b <sub>5</sub>	mm	560/685/776	560/685/776
4.32		Ground clearance, centre of wheelbase	m <sub>2</sub>	mm	60 <sup>3)</sup>	60 <sup>3)</sup>
4.33		Aisle width for pallets 1000 x 1200 crossways	A <sub>st</sub>	mm	1500	1400
4.34		Aisle width for pallets 800 x 1200 lengthways	A <sub>st</sub>	mm	1250	1200
4.35	Turning radius	W <sub>a</sub>	mm	1660	1660	
4.41	Transfer aisle width, 800 x 1200 lengthways	Au	mm	3140	3140	
4.44	Clear width driver compartment entrance	l <sub>24</sub>	mm	425	425	
Performance data	5.1	Travel speed, with/without load		km/h	9,0/9,0	9,0/9,0
	5.2	Lift speed, with/without load		m/s	0,20/0,25	0,20/0,25
	5.3	Lowering speed, with/without load		m/s	0,40/0,37	0,40/0,37
	5.9	Acceleration time (0-10 meters), with/without load		s	6,9/5,9	6,9/5,9
	5.10	Service brake			Electric	Electric
Electric motor	6.1	Drive motor rating S2 60 min		kW	1,8	1,8
	6.2	Lift motor rating S3 20%		kW	5,0	5,0
	6.4	Battery voltage, nominal capacity K <sub>s</sub>		V/Ah	24/500	24/500
	6.5	Battery weight		kg	375	375
	6.6	Energy consumption acc to VDI cycle <sup>5)</sup>		kWh/h		
	Other	8.1	Type of drive control			Transistor stepless
8.4		Sound level at the driver's ear according to EN 12 053		dB(A)	< 61	< 61
8.6		Steering			Electric	Electric

1) With adjustable fork add 38 mm to l<sub>2</sub> and x.

2) b<sub>1</sub>=chassis width, b<sub>2</sub>=cab width.

3) 25 mm if wire guided.

4) Measured according to company standard.

5) Contact your supplier for information.

All data are based on table configuration. Other configurations may give other values.

Truck performance and dimensions are nominal and subject to tolerances.

BT products and specifications are subject to change without notice.

# Mast dimensions

# BT optio

Mast				OME100M					OME100
	Platform height	$h_{12}$	mm	2000	2950	3600	4200	4700	1750
OME100M, OME100	Height, mast lowered	$h_1$	mm	2400	2400	2400	2650	2900	1460
	Lift movement	$h_3$	mm	1700	2650	3300	3900	4400	1450
	Height, mast extended	$h_4$	mm	4150	5080	5760	6350	6850	2940
	Auxiliary lift movement	$h_9$	mm	780	780	780	780	780	780
	Picking height	$h_{28}$	mm	3600	4550	5200	5800	6300	3350
	Total lift height	$h_{23}$	mm	2560	3510	4160	4760	5260	2310

# Working aisle widths

OME100M, OME100	Standard values			Rail guided trucks				Wire guided trucks			
				EUR pallet		CHEP pallet		EUR pallet		CHEP pallet	
	Handling type		mm	LS	SS	LS	SS	LS	SS	LS	SS
	Pallet length		mm	800	1200	1000	1200	800	1200	1000	1200
	Pallet width		mm	1200	800	1200	1000	1200	800	1200	1000
	Chassis width	$b_1$	mm	970	970	970	970	970	970	970	970
	Distance between pallets in aisle	$Ast$	mm	1400	1200	1400	1200	1500	1250	1500	1300
	Transfer aisle, VDI Theoretical <sup>1)</sup>	$Ast_3$	mm	2848	3140	3024	3170	2848	3140	3024	3170
	Transfer aisle, Practical <sup>1)</sup>	$Ast_3$	mm	3348	3640	3524	3670	3848	4140	4024	4170

1) For machines with adjustable forks, add +40 mm to the above values.

LS = Long side pallet handling.

SS = Short side pallet handling.

OME100M

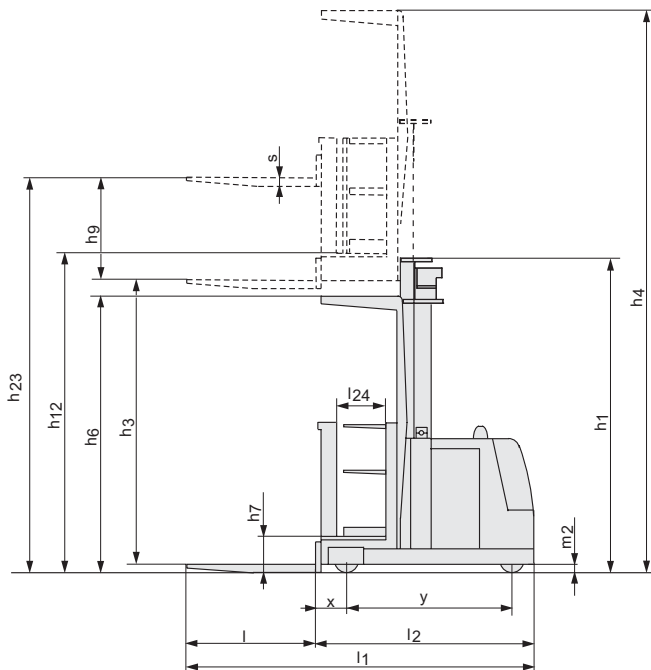

OME100

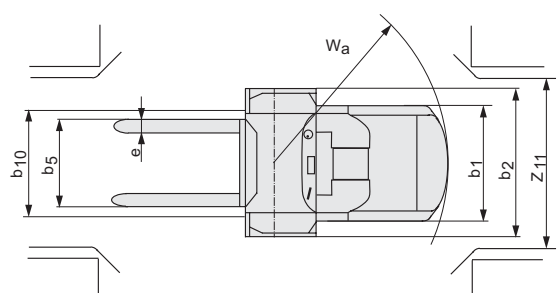
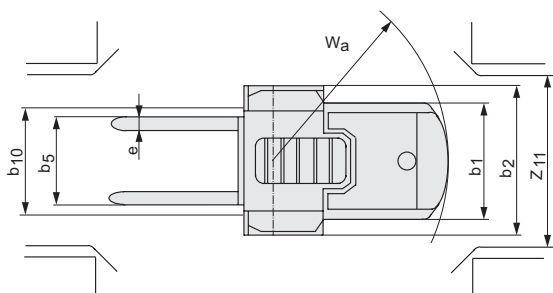
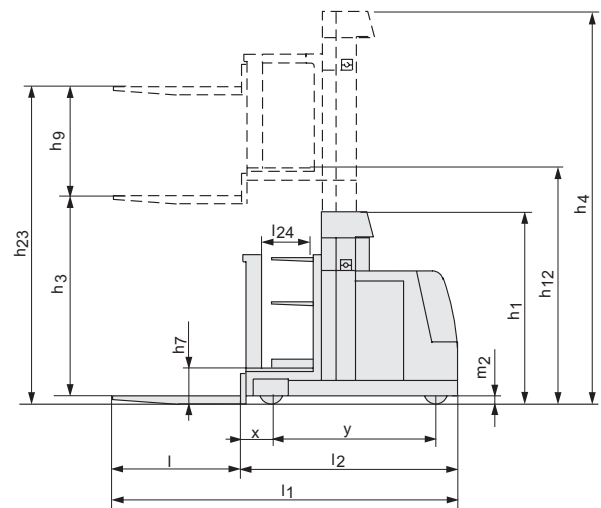

## Truck features:

- BT Optipace system
- Clear-view mast
- Driver detection system
- Elevating platform
- Height adjustable control panel with intuitive controls.
- Information display showing all vital information
- Programmable performance
- Controls, display and backrest can be switched from front to rear or vice versa within minutes.
- Wire/rail guidance
- Electronic braking system
- Adjustable backrest
- Storage compartments

