

Very narrow aisle truck 1.25 ton

BT vector

R-series

VRE125SF



Very Narrow Aisle truck

Truck specifications					VRE125SF
Identification	1.1	Manufacturer			BT
	1.2	Model			VRE125SF
	1.3	Drive			Electric
	1.4	Operator type			Seated
	1.5	Load capacity/rated load	Q	kg	1250
	1.6	Load centre	c	mm	600
	1.9	Wheelbase	y	mm	2137/2537
Weight	2.1	Service weight including battery		kg	4630
	2.2	Axle load, with load, drive/support arm wheel		kg	2411/3477
	2.3	Axle load, without load, drive/support arm wheel		kg	1983/2647
Wheels	3.1	Drive/support arm wheel			Vulkollan
	3.2	Wheel size, front		mm	Ø 230x110
	3.3	Wheel size, rear		mm	Ø 400x160
	3.5	Wheels, number front/rear (x=driven wheels)			4/1x
	3.6	Track width, front	b ₁₀	mm	1220
	Dimensions	4.2	Height, mast lowered	h ₁	mm
4.3		Free lift	h ₂	mm	2090 *
4.4		Lift	h ₃	mm	6035 *
		Lift height	h ₂₃	mm	6400 *
4.5		Height, mast extended	h ₄	mm	7965 *
4.7		Height of overhead guard	h ₆	mm	2261
4.8		Seat height	h ₇	mm	1100
4.15		Height of lowered forks	h ₁₃	mm	365
4.19		Overall length	l ₁	mm	2740/3140
4.21		Overall width	b ₁	mm	1375/1490
4.22		Fork dimensions	s/e/l	mm	75/180/1200 *
4.25		Width over forks	b ₅	mm	550
4.31		Ground clearance, with load, below mast	m ₁	mm	70
4.32		Ground clearance, centre of wheelbase	m ₂	mm	60
4.34		Aisle width for pallets 800 x 1200 lengthways	A _{st}	mm	1450 *
4.35	Turning radius	W _a	mm	2389/2789	
Performance data	5.1	Travel speed, with/without load		km/h	11,25/14
	5.2	Lift speed, with/without load		m/s	0,40/0,50
	5.3	Lowering speed, with/without load		m/s	0,50/0,48
	5.9	Acceleration time, with/without load (0-10m)		s	5,7/5,2
	5.10	Service brake			Electric
Electric motor	6.1	Drive motor rating S2 60 min		kW	7,5
	6.2	Lift motor rating S3 15%		kW	15
	6.4	Battery voltage, nominal capacity K ₅		V/Ah	48/620 *
	6.5	Battery weight		kg	956 *
	6.6	Energy consumption acc to VDI cycle ¹⁾		kWh/h	
	Other	8.1	Type of drive control		
8.4		Sound level at the driver's ear according to EN 12 053		dB(A)	61

1) Contact your supplier for information

* Other dimensions available

Truck performance and dimensions are nominal and subject to tolerances.

BT products and specifications are subject to change without notice.

Mast dimensions

BT vector

Mast				Triplex Hi-Lo										
VRE125SF	Lift height	h_{23}	mm	4600	5200	5800	6400	7300	7900	8500	9100	9700	10300	11300
	Lift	h_3	mm	4525	5125	5725	6325	7225	7825	8425	9025	9625	10225	11225
	Height, mast lowered	h_1	mm	2535	2735	2935	3135	3570	3770	3970	4170	4505	4705	5035
	Free lift	h_2	mm	1490	1690	1890	2090	2524	2724	2924	3124	3458	3658	3990
	Height, mast extended	h_4	mm	5265	5865	6465	7065	7965	8565	9165	9765	10365	10965	11965

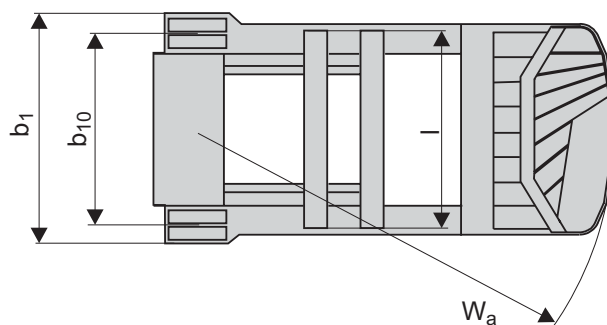
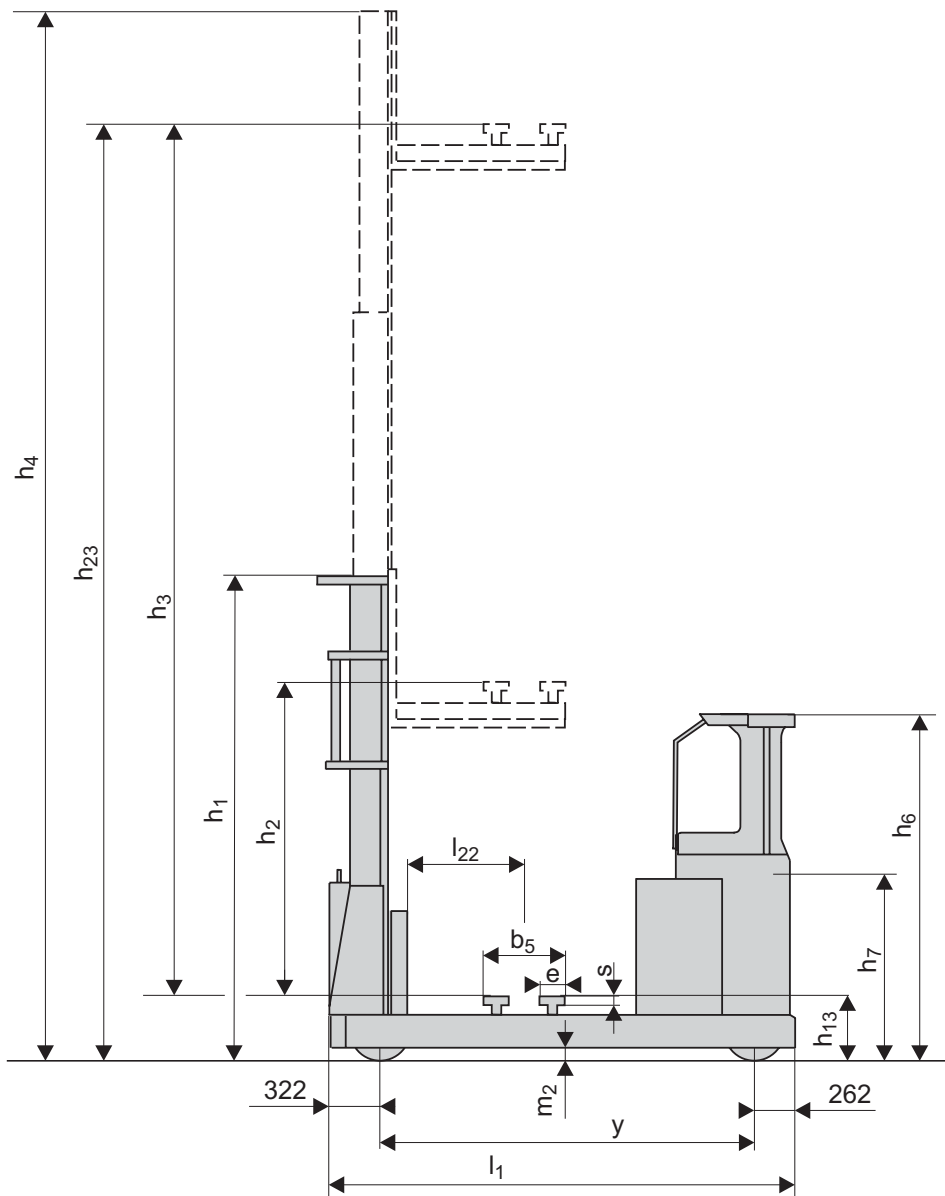

Truck features:

- Total view concept
- Car pedal layout
- Automatic parking brake
- TLC, Transitional Lift Control
- 360° steering
- Simultaneous hydraulic control
- Single function levers or multi function control
- Heavy duty drive unit and gear box

