

# Order picking truck 1.0 ton



**BT optio**

*M-series*

OME100MW

OME100W



**TOYOTA**

MATERIAL HANDLING

stronger together

# Order picking truck

Truck specifications					OME100MW	OME100W
Identification	1.1	Manufacturer			BT	BT
	1.2	Model			OME100MW	OME100W
	1.3	Drive			Electric	Electric
	1.4	Operator type			Stand on	Stand on
	1.5	Load capacity/rated load	Q	kg	850/1000	850/1000
	1.6	Load centre	c	mm	600/500	600/500
	1.8	Load distance, centre of load axle to fork	x	mm	225	225
	1.9	Wheelbase	y	mm	1441	1441
	Weight	2.1	Service weight with battery		kg	1995
2.2		Axle load, with load, drive/fork wheel		kg	697/1228	609/1135
2.3		Axle load, without load, drive/fork wheel		kg	1176/490	1058/410
Wheels	3.1	Drive/fork wheel			Vulkollan	Vulkollan
	3.2	Wheel size, front		mm	Ø 230 x 85	Ø 230 x 85
	3.3	Wheel size, rear		mm	Ø 250 x 75	Ø 250 x 75
	3.5	Wheels, number front/rear (x=driven wheels)			2/1 (*)	2/1 (*)
	3.6	Track width, front	b <sub>10</sub>	mm	850	850
	Dimensions	4.2	Height, mast lowered	h <sub>1</sub>	mm	2650
4.4		Lift	h <sub>3</sub>	mm	3900	1450
		Lift height	h <sub>23</sub>	mm	3980	1530
4.5		Height, mast extended	h <sub>4</sub>	mm	6350	2940
4.7		Height of overhead guard (cab)	h <sub>6</sub>	mm	2390	—
4.8		Stand height	h <sub>7</sub>	mm	300	300
4.11		Initial lift movement	h <sub>9</sub>	mm	—	—
4.14		Stand height, elevated	h <sub>12</sub>	mm	4200	1750
4.14.1		Picking height (h <sub>12</sub> + 1600 mm)	h <sub>28</sub>	mm	5800	3350
4.19		Overall length	l <sub>1</sub>	mm	2770/2970/3170	2770/2970/3170
4.20		Length to face of forks	l <sub>2</sub>	mm	1870	1870
4.21		Overall width <sup>1)</sup>	b <sub>1</sub> /b <sub>2</sub>	mm	970/1000	970/970
4.22		Fork dimensions	s/e/l	mm	62/115/850	62/115/850
4.25		Width over forks	b <sub>5</sub>	mm	560/685/776	560/685/776
4.32		Ground clearance, centre of wheelbase	m <sub>2</sub>	mm	60 <sup>2)</sup>	60 <sup>2)</sup>
4.33		Aisle width for pallets 1000 x 1200 crossways	A <sub>st</sub>	mm	1710	1610
4.34		Aisle width for pallets 800 x 1200 lengthways	A <sub>st</sub>	mm	1310	1210
4.35	Turning radius	W <sub>a</sub>	mm	1660	1660	
4.41	Transfer aisle width, 800 x 1200 lengthways	A <sub>u</sub>	mm	3270	3270	
4.44	Clear width driver compartment entrance	l <sub>24</sub>	mm	425	425	
Performance data	5.1	Travel speed, with/without load		km/h	9,0/9,0	9,0/9,0
	5.2	Lift speed, with/without load		m/s	0,20/0,25	0,20/0,25
	5.3	Lowering speed, with/without load		m/s	0,40/0,37	0,40/0,37
	5.9	Acceleration time (0-10 meters), with/without load		s	6,9/5,9	6,9/5,9
	5.10	Service brake			Electric	Electric
Electric motor	6.1	Drive motor rating S2 60 min		kW	1,8	1,8
	6.2	Lift motor rating S3 20%		kW	5,0	5,0
	6.4	Battery voltage, nominal capacity K <sub>s</sub>		V/Ah	24/500	24/500
	6.5	Battery weight		kg	375	375
	6.6	Energy consumption acc to VDI cycle <sup>3)</sup>		kWh/h		
	Other	8.1	Type of drive control			Transistor stepless
8.4		Sound level at the driver's ear according to EN 12 053		dB(A)		
8.6		Steering			Electric	Electric

1) b<sub>1</sub>=chassis width, b<sub>2</sub>=cab width

2) 25 mm if wire guided.

3) Contact your supplier for information.

All data are based on table configuration. Other configurations may give other values.

Truck performance and dimensions are nominal and subject to tolerances.

BT products and specifications are subject to change without notice.

# Mast dimensions

# BT optio

Mast				OME100MW					OME100W
Platform height	$h_{12}$	mm	2000	2950	3600	4200	4700	1750	
OME100MW, OME100W	Height, mast lowered	$h_1$	mm	2400	2400	2400	2650	2900	1460
	Lift movement	$h_3$	mm	1700	2650	3300	3900	4400	1450
	Height, mast extended	$h_4$	mm	4150	5080	5760	6350	6850	2940
	Picking height	$h_{28}$	mm	3600	4550	5200	5800	6300	3350
	Total lift height	$h_{23}$	mm	1780	2730	3380	3980	4480	1530

# Working aisle widths

Standard values	Rail guided trucks				Wire guided trucks					
	EUR pallet		CHEP pallet		EUR pallet		CHEP pallet			
	LS	SS	LS	SS	LS	SS	LS	SS		
Handling type										
Pallet length		mm	800	1200	1000	1200	800	1200	1000	1200
Pallet width		mm	1200	800	1200	1000	1200	800	1200	1000
Load frame inner dim, (b21 x l 21)		mm	1290x820	890x1220	1290 x 1020	1090 x 1220	1290 x 820	890 x 1220	1290 x 1020	1090 x 1220
Load frame outer dim, (b22 x l 22)		mm	1410 x 900	1010x1300	1410x1100	1210x1300	1410x900	1010x1300	1410x1100	1210x1300
Chassis width	$b_1$	mm	970	970	970	970	970	970	970	970
Distance between pallets in aisle	$Ast$	mm	1710	1310	1710	1510	1710	1310	1710	1510
Transfer aisle, VDI Theoretical	$Ast_3$	mm	2990	3270	3165	3300	2990	3270	3165	3300
Transfer aisle, Practical	$Ast_3$	mm	3490	3770	3665	3800	3990	4270	4165	4300

LS = Long side pallet handling  
SS = Short side pallet handling

OME100MW

OME100W

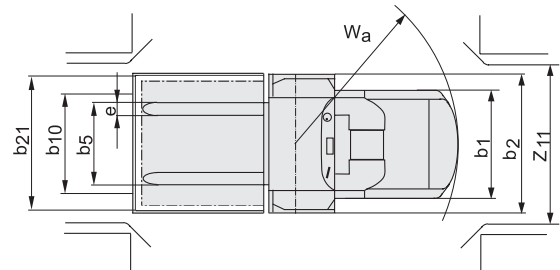
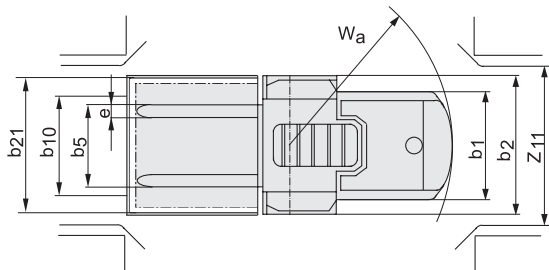
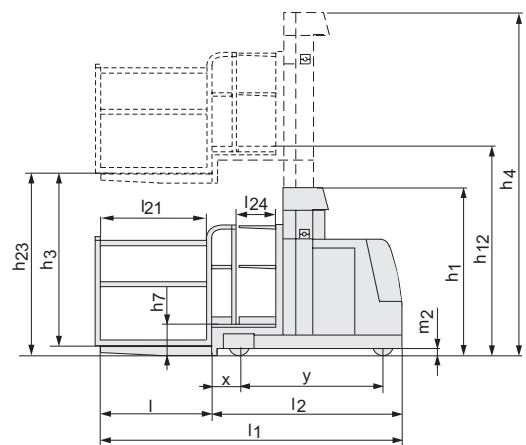
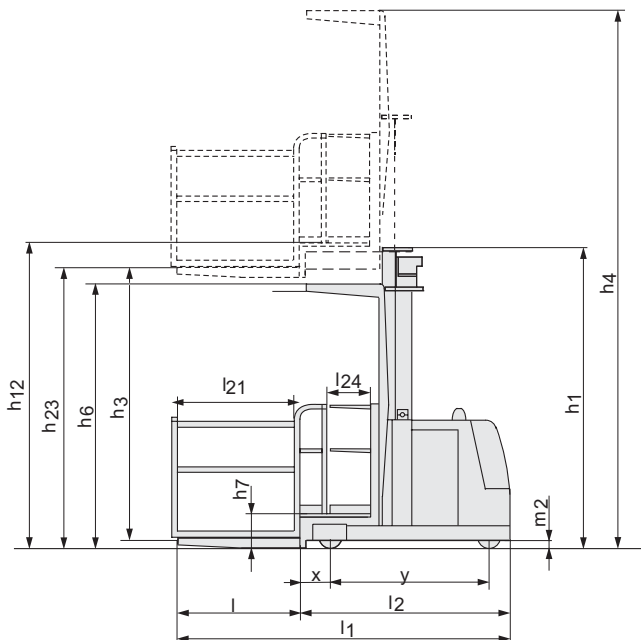

## Truck features:

- BT Optipace system
- Clear-view mast
- Driver detection system
- Elevating platform
- Height adjustable control panel with intuitive controls.
- Information display showing all vital information
- Programmable performance
- Wire/rail guidance
- Electronic braking system
- Adjustable backrest
- Storage compartments

