

Platform lowlifter truck 2.0 - 2.5 ton

BT levio

P-series

LPE200

LPE220

LPE250



Platform lowlifter

Specification for lowlifter trucks					LPE200			LPE220		LPE250
Identification	1.1	Manufacturer			Toyota	Toyota	Toyota	Toyota	Toyota	Toyota
	1.2	Model			LPE200	LPE200	LPE200	LPE220	LPE220	LPE250
	1.3	Drive			Electric	Electric	Electric	Electric	Electric	Electric
	1.4	Operator type			Stand on/pedestrian					
	1.5	Load capacity/rated load	Q	kg	2000	2000	2000	2200	2200	2500
	1.6	Load centre	c	mm	600	600	600	600	600	600
	1.8	Load distance, centre of support arm wheel to face of fork, fork raised/lowered	x	mm	913/957*	913/957*	913/957*	913/957*	913/957*	913/957*
	1.9	Wheelbase, fork raised/lowered	y	mm	1362/1406*	1362/1406*	1362/1406*	1410/1454*	1410/1454*	1410/1454*
	Weight	2.1	Service weight with battery		kg	718	718	718	826	826
2.2		Axle load, with load, drive/castor/fork wheel		kg	466/585/1667	466/585/1667	466/585/1667	679/834/1513	679/834/1513	641/911/1774
2.3		Axle load, without load, drive/castor/fork wheel		kg	284/294/140	284/294/140	284/294/140	389/311/126	389/311/126	389/311/126
Wheels	3.1	Drive/castor/fork wheel			Vulkollan®/Vulkollan®/Vulkollan®					
	3.2	Wheel size, front		mm	Ø 230x70	Ø 230x70	Ø 250x75	Ø 230x70	Ø 250x75	Ø 250x75*
	3.3	Wheel size, rear		mm	Ø 85x95	Ø 85x95	Ø 85x95	Ø 85x95	Ø 85x95	Ø 85x95
	3.4	Additional wheels (dimensions)		mm	Ø 125x50*	Ø 125x50*	Ø 125x50*	Ø 125x50*	Ø 125x50*	Ø 150x54*
	3.5	Wheels, number front/rear (x = driven wheels)			1x+ 2/2 or 4	1x+ 2/2 or 4	1x+ 2/2 or 4	1x+ 2/2 or 4	1x+ 2/2 or 4	1x+ 2/2 or 4
	3.6	Track width, front	b ₁₀	mm	500	500	500	500	500	500
	3.7	Track width, rear	b ₁₁	mm	370	370	370	370	370	370
Dimensions	4.4	Lift		h ₃	mm	120 ¹⁾	120 ¹⁾	120 ¹⁾	120 ¹⁾	120 ¹⁾
		Lift height		h ₂₃	mm	205 ¹⁾	205 ¹⁾	205 ¹⁾	205 ¹⁾	205 ¹⁾
	4.8	Stand height		h ₇	mm	190	190	190	190	190
	4.9	Height of tiller in drive position, min./max.								
		Manual steering		h ₁₄	mm	1100/1413	1100/1413	1100/1413	1100/1413	1100/1413
		Power steering, highest setting		h ₁₄	mm	1201/1413	1201/1413	1201/1413	1201/1413	1201/1413
		Power steering, lowest setting		h ₁₄	mm	1101/1313	1101/1313	1101/1313	1101/1313	1101/1313
	4.15	Height, fork lowered		h ₁₃	mm	85	85	85	85	85
	4.19	Overall length		l ₁	mm	1816*	1816*	1816*	1864*	1864*
	4.20	Length to face of forks		l ₂	mm	666*	666*	666*	714*	714*
	4.21	Overall width		b ₁	mm	730	730	730	730	730
	4.22	Fork dimensions		s/e/l	mm	78/180/1150*	78/180/1150*	78/180/1150*	78/180/1150*	78/180/1150*
	4.25	Width over forks		b ₅	mm	550*	550*	550*	550*	550*
	4.32	Ground clearance, centre of wheelbase		m ₁	mm	30	30	30	30	30
4.33	Aisle width for pallets 1000x1200 crossways		A _{st}	mm	2430*	2430*	2430*	2477*	2477*	
4.34	Aisle width for pallets 800x1200 lengthways		A _{st}	mm	2277*	2277*	2277*	2324*	2324*	
4.35	Turning radius, fork raised		W _a	mm	1585*	1585*	1585*	1632*	1632*	
Performance data	5.1	Travel speed, with/without load								
		Manual steering		km/h	6,0/6,0	8,0/8,0	8,0/10,0	7,5/8,0	7,5/10,0	7,0/12,5
		Power steering		km/h	6,0/6,0	8,0/8,0	9,0/10,0	8,0/8,0/8	9,0/10,0	11,0/12,5
	5.2	Lift speed, with/without load		m/s	0,05/0,08	0,05/0,08	0,05/0,08	0,05/0,07	0,05/0,07	0,05/0,07
	5.3	Lowering speed, with/without load		m/s	0,11/0,09	0,11/0,09	0,11/0,09	0,11/0,08	0,11/0,08	0,09/0,09
	5.8	Max. gradeability, with/without load ²⁾		%	8/18	8/18	8/18	8/18	8/18	8/18
5.9	Acceleration time (over 10 m)		s	5,7	5,7	5,7	5,0	5,0	4,7	
5.10	Service brake				Electromagnetic					
Electric motor	6.1	Drive motor rating S2 60 min		kW	1,8	2,5	2,5	2,5	2,5	2,8
	6.2	Lift motor rating at S3 10%		kW	2,2	2,2	2,2	2,2	2,2	2,2
	6.4	Battery voltage/nominal capacity K _s		V/Ah	24/300*	24/300*	24/300*	24/400*	24/400*	24/400*
	6.5	Battery weight		kg	241	241	241	305	305	305
	6.6	Energy consumption acc. to VDI cycle		kWh/h		0,46			0,52	0,55
	8.1	Type of drive control				Variable AC	Variable AC	Variable AC	Variable AC	Variable AC

1) +20 mm for roll container handling.

2) Measured according to company standard.

*) Further alternatives are available and will produce other values.

All data are based on table configuration. Other configurations may give other values.

Truck performance and dimensions are nominal and subject to tolerances.

Toyota Material Handling Manufacturing Sweden AB products and specifications are subject to change without notice.

Battery dependent dimensions

Dimensions		Battery change		Lift out			Sideways			Li-ion	
		Compartment		Small	Medium	Large/DIN	Small	Medium	Large/DIN	Small	Medium
1.9	Wheelbase, fork raised/lowered	y	mm	1406/1362	1454/1410	1551/1507	1466/1422	1514/1470	1608/1564	1406/1362	1454/1410
4.19	Overall length										
	with platform up/down	l_1	mm	1816/2266	1864/2314	1961/2411	1876/2326	1924/2374	2021/2471	1816/2266	1864/2314
	with backrest	l_1	mm	2440	2488	2585	2500	2548	2645	2440	2488
	with fixed side protection	l_1	mm	2276	2324	2420	2336	2384	2480	2276	2324
4.20	Length to face of forks										
	with platform up/down	l_2	mm	666/1116	714/1164	811/1261	726/1176	774/1224	871/1321	666/1116	714/1164
	with backrest	l_2	mm	1290	1338	1435	1350	1398	1495	1290	1338
	with fixed side protection	l_2	mm	1126	1174	1270	1186	1234	1330	1126	1174
4.33	Aisle width for pallets 1000x1200 crossways										
	with platform up/down	A_{st}	mm	2430/2894	2477/2942	2572/3038	2489/2953	2536/3001	2631/3097	2430/2894	2477/2942
	with backrest	A_{st}	mm	3066	3114	3210	3126	3174	3270	3066	3114
	with fixed side protection	A_{st}	mm	2904	2951	3047	2963	3011	3106	2904	2951
4.34	Aisle width for pallets 800x1200 lengthways										
	with platform up/down	A_{st}	mm	2277/2741	2324/2789	2419/2885	2336/2801	2383/2848	2478/2944	2277/2741	2324/2789
	with backrest	A_{st}	mm	2914	2961	3058	2973	3021	3117	2914	2961
	with fixed side protection	A_{st}	mm	2751	2799	2894	2811	2858	2953	2751	2799
4.35	Turning radius, fork raised										
	with platform up/down	W_a	mm	1585/2049	1632/2096	1727/2193	1644/2108	1691/2156	1786/2252	1585/2049	1632/2096
	with backrest	W_a	mm	2221	2269	2365	2281	2329	2425	2221	2269
	with fixed side protection	W_a	mm	2059	2106	2202	2118	2166	2261	2059	2106
6.4	Battery voltage, nominal capacity K_3		V/Ah	24/225-300	24/400	24/375-600	24/225-300	24/400	24/375-600	24/100-150	24/200
6.5	Battery weight		kg	175-285	265-350	375-485	175-285	265-350	375-485	126/90	90/102

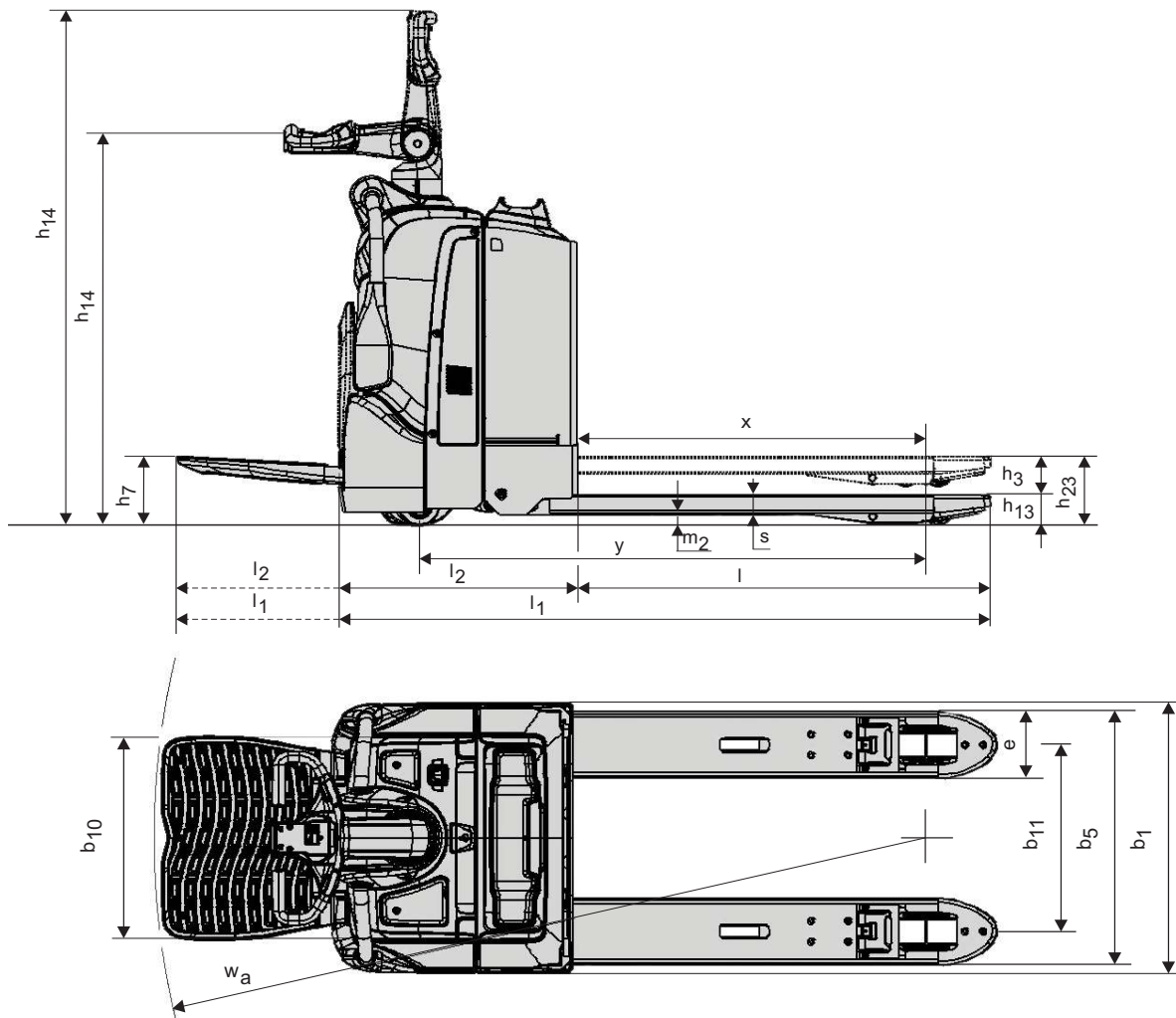

Truck features:

- BT Powertrak traction system
- Fingertip controls
- Information display
- Electronic braking system
- Electronic regenerative brakes
- Driver detection system
- Sideways battery change



TP-Technical Publications, Sweden — 746909-040, version 2, 2017-01-11

TOYOTA

MATERIAL HANDLING